

OCEAN MULTI SEESAW

M187

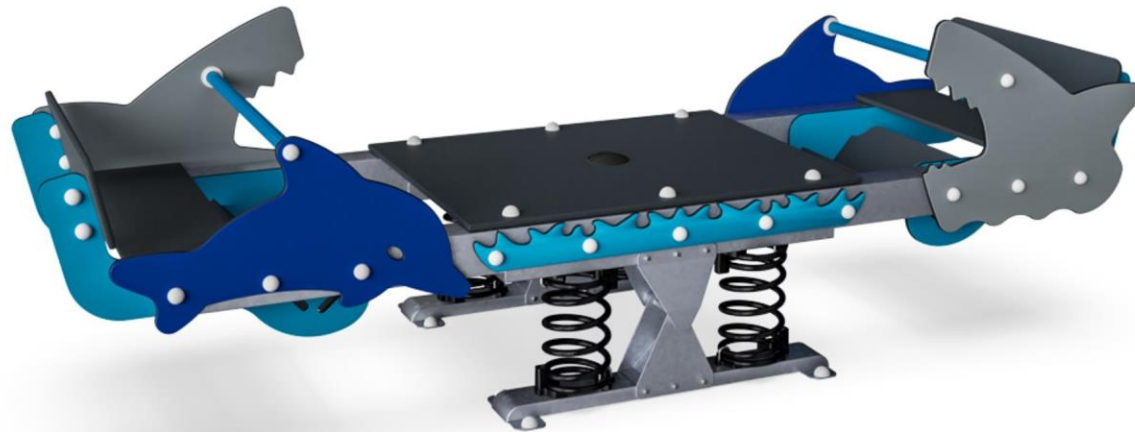

Item no. M18701-01P	
General Product Information	
Dimensions LxWxH	3'3" x 10'4" x 3'3"
Age Group	2-5
Play Capacity	10 children
Color Options	

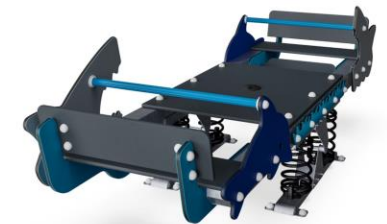

The Ocean Multi Seesaw motivates children to join in play, rocking together. The spacious design and sturdy back and foot support allow for many children of all abilities playing together. The risk seekers can stand on the middle platform securely, sensing the movement of the others. The spacious platform also allows for socializing and children lying or

sitting. There is room enough for caregivers, too. The seats at the end are big enough for older children as well as adults. The fun thrill of rocking, individually, in small or in big groups, will make children return for more. Rocking on the Ocean Multi Seesaw trains the children's muscles and motor skills, their balance and coordination. The spaciousness of the seesaw

supports development of social-emotional skills, e.g. cooperation, consideration and turn-taking. Toddlers experience cause-and-effect understanding.

OCEAN MULTI SEESAW

M187



Panels of 3/4" EcoCore™. EcoCore™ is a highly durable, eco-friendly material, which is not only recyclable after use, but also consists of a core produced from 100% recycled material.



KOMPAN Springs are made of high-quality spring steel according to EN10270. The springs are cleaned by phosphating before they are painted with an epoxy primer and a polyester powder coating as top finish.



The springs are fixed by unique anti pinch fittings for maximum safety and long lifetime.



The steel surfaces are hot dip galvanized inside and outside with lead free zinc. The galvanization has excellent corrosion resistance in outside environments and is maintenance free.



Platform and seats are made of HPL with a thickness of .7" with a very high wearing strength and a unique KOMPAN nonskid surface texture.



Footrests are made of high-quality stainless steel. The steel is cleaned by a total pickling process after manufacturing.

Item no. M18701-01P	
Installation Information	
Max. fall height	3'3"
Safety surfacing area	353.1 ft²
Numbers of Installers (persons)	2
Total installation time	8
Excavation volume	0.55 yd³
Concrete volume	0 yd³
Footing Depth (Standard)	1' 5"
Shipment Weight	646 lbs
Anchoring options	In-ground ✓
Warranty information	
Panels	Lifetime
Springs	5 Years
HPL plate	10 Years
Galvanized steel	10 Years
Spare parts guaranteed	10 Years

Elevated Activities	Accessible Elevated Activities	Accessible Ground Level Activities	Accessible Ground Level Play Types
Present	0	1	1
Required	0	1	1

OCEAN MULTI SEESAW

M187

Max fall height | Total height | Safety surfacing area

Max fall height | Total height

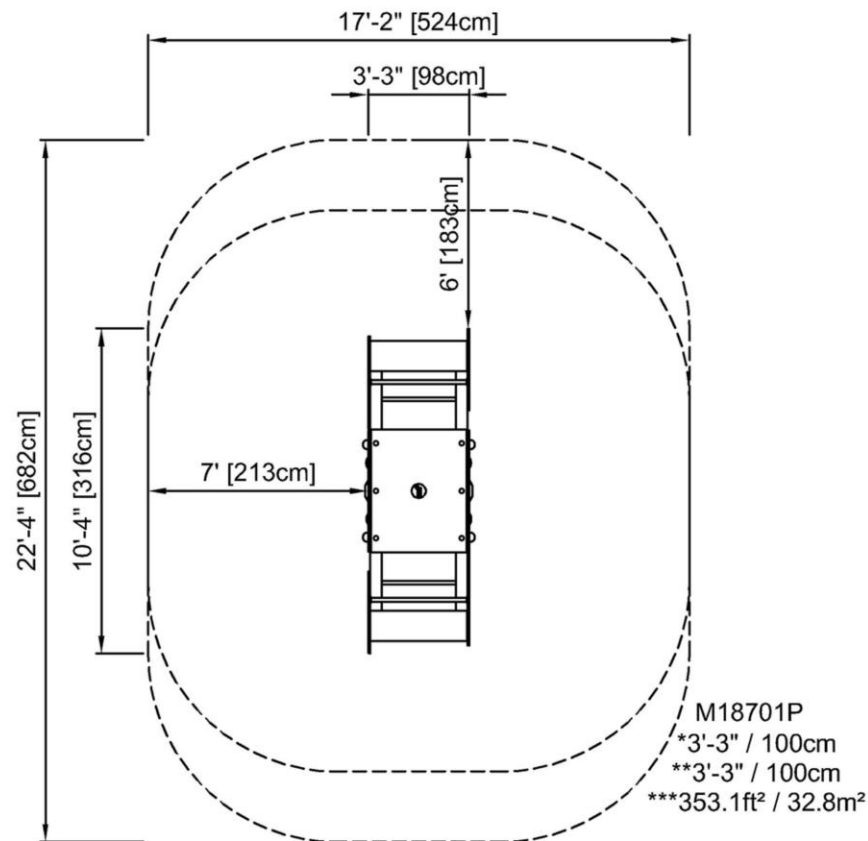

M18701P
1:100

[Click to see 1:100 ratio TOP VIEW](#)

[Click to see 1:100 ratio SIDE VIEW](#)

OCEAN MULTI SEESAW

M187



Handhold

Physical: the possibility to hold onto more areas of the handhold ensures a good grip, necessary for rocking intensely. This trains the hand and arm muscles.



Center platform

Physical: supports agility, balance and coordination when standing, using leg and core muscles, building bone density when jumping. Facilitate sitting and lying also, allowing for users with disabilities.

Social-Emotional: provides an inclusive space. Point for gathering and for caregivers assisting. Teamwork and socializing when rocking together.



Double seating option

Social-Emotional: the possibility of two rocking together supports cooperation skills. Furthermore, the physical contact with others is great for the well-being of children, measurable in lower cortisol (stress hormone) levels.



Foot support

Physical: the possibility of foot rest supports intensive rocking. Rocking stimulates the senses of balance and space that are fundamental in managing the world securely.

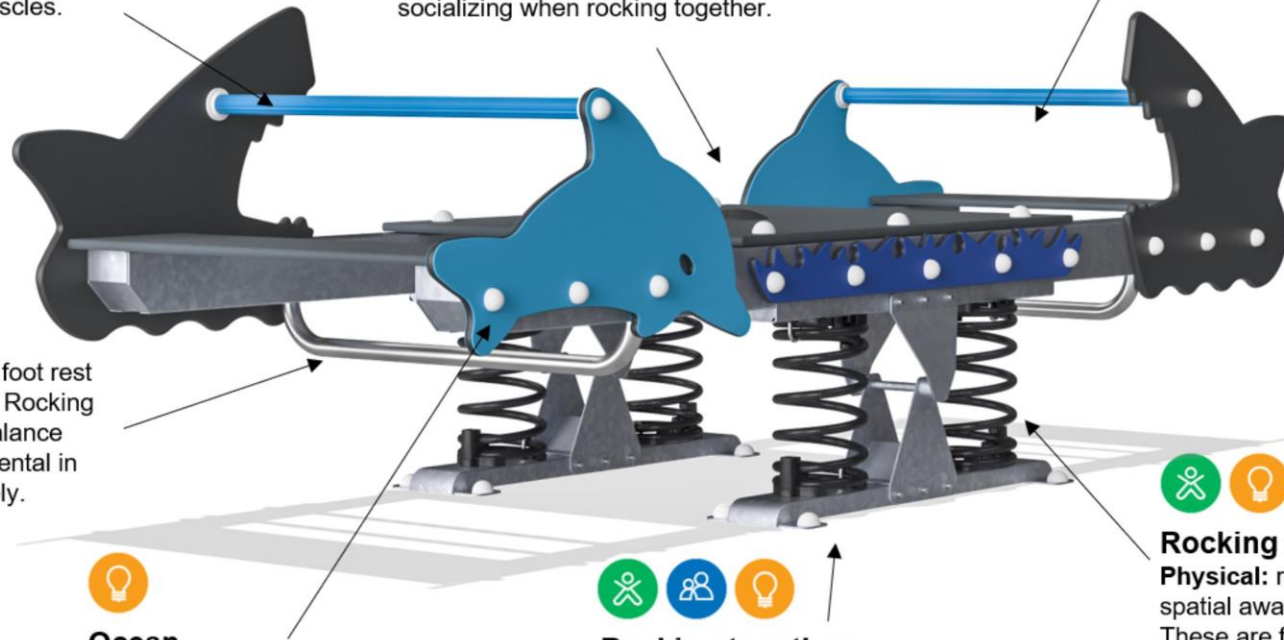

Ocean

Cognitive: suggests a theme and supports dramatic play, which stimulates languages and communication skills.



Rocking together

Physical: rocking promotes sense of balance and space, both important in for navigating the body confidently in space.

Social-Emotional: consideration of others when rocking.

Cognitive: cause and effect understanding for younger children.



Rocking spring

Physical: response to movements adds to spatial awareness and sense of balance. These are fundamental motor skills that help the child's ability to sit still on a chair which takes a good sense of balance.

Cognitive: trains the understanding of cause and effect: when I move my body, the spring responds with movement.

OCEAN MULTI SEESAW

M187



PHYSICAL
Joy of movement:
motor skills, muscle, cardio
and bone density



SOCIAL-EMOTIONAL
Joy of being together:
teamwork, tolerance and
sense of belonging



COGNITIVE
Joy of learning:
curiosity, understanding of causal
relationships and knowledge of the world



CREATIVE
Joy of creating:
co-creation and experimenting
with materials



BALANCE
To balance is to stay upright when walking or standing on a surface that makes this challenging (e.g. a wobbly, inclined, or narrow surface).



HANG IN ARMS
To hang in arms is the act of carrying the body with the hands or arms, possibly to traverse to another platform or play item.



SENSORY
To sense is the act of taking in information with the sensory system: seeing, feeling, hearing or sensing with the body.



BOUNCE
To bounce is the act of bouncing on a responsive, flexible, elastic or tensile surface.



JUMP
To jump is the act of jumping up or down on a hard surface.



SLIDE
To slide is the act of moving fast downwards seated on a slide.



CLIMB
To climb is the act of moving upwards, cross-coordinating arms and legs, on a vertical or inclined surface or net.



PULL
To pull is the act of pulling an item towards you or you towards an item with one or both hands, or possibly using the entire body.



SOCIALIZE
To socialize is the act of meeting, communicating or cooperating in an activity that stimulates and facilitates social interaction.



CONSTRUCT
To construct is the act of creating new patterns, shifting items or materials to new positions or constructing with materials that can be transformed or manipulated.



PUSH
To push is the act of pushing an item away from you with one or both hands, possibly with the entire body.



SPIN
To spin involves a fast, repeated horizontal or vertical turn of the body on a piece of equipment that facilitates the movement.



CRAWL
To crawl is the movement of moving forwards or backwards, cross-coordinating arms and legs, on a horizontal or slightly inclined surface.



ROCK
To rock is the action of rocking back and forth, or sideways, on e.g. a piece of spring equipment.



SWAY
To sway is the movement of swaying back and forth, or around, lying, seated or possibly standing, in a pendulant or circular movement, e.g. on a hammock or on a rope.



DRAMATIC PLAY
Dramatic play is motivated through play items that stage a frame, place or environment for acting out make believe or role play scenarios.



ROTATE
To rotate involves a vertical or horizontal slower paced turn of the body, facilitated by a piece of equipment.



SWING
To swing is the movement of swinging back and forth, or in circular movement, seated, standing or lying, in an unhindered arc.



GLIDE
To glide is the act of moving from one point to another without shifting the feet, in a horizontal or vertical movement, in a seated, lying or standing position, letting gravity do the work.



RULES PLAY
Rules play is motivated through play items that suggest games-with-rules, cooperation and team work, e.g. tic-tac-toe, timers or ball games.



WONDER
To wonder is motivated through play items that make children need and use their logical, abstract or creative thinking skills, as well as their memory.